

greenfan®

bipolar ionizer

Model 1600-01

INSTALLATION, OPERATION, AND MAINTENANCE INSTRUCTIONS

Intertek® Verified
Zero Ozone
Meets UL 2998
CARB Certified
Certified to
CSA C22.2 #187
Conforms to UL 867



Document No.: GF-IFU-1600-01

Revision: 1.0.1

Release Date: 2026-05-13

files.greenfan.co/bbi_instructions.pdf

U.S. Patents 11,173,226 B1; 11,563,310 B2; 12,038,204 B2

greenfan® bipolar ionizer Model 1600-01

TABLE OF CONTENTS

1.0 INTRODUCTION	1
2.0 TOOLS FOR INSTALLATION AND MAINTENANCE	3
3.0 DISCONNECT POWER BEFORE INSTALLATION	4
4.0 HVAC FAN INSTALLATION	4
4.1 HVAC Fan Mechanical Installation	4
4.2 HVAC Fan Electrical Installation with 24VAC Transformer	5
4.3 HVAC Fan Verification of Proper Operation	7
5.0 AIR PURIFIER INSTALLATION.....	7
5.1 Air Purifier Mechanical Installation	7
5.2 Air Purifier Electrical Installation	8
5.3 Air Purifier Verification of Proper Operation	8
6.0 VENTILATION FAN INSTALLATION	9
6.1 Ventilation Fan Mechanical Installation	9
6.2 Ventilation Fan Electrical Operation	10
6.3 Ventilation Fan Verification of Proper Operation	10
7.0 OPERATING NOTES	10
8.0 TROUBLESHOOTING	11
9.0 MAINTENANCE	11
10.0 SAFETY INSTRUCTIONS.....	12
11.0 WARRANTY	12
12.0 SPECIFICATIONS.....	14

greenfan® bipolar ionizer Model 1600-01

1.0 INTRODUCTION

These installation, operation, and maintenance instructions describe how the greenfan® bipolar ionizer shown in **Figure 1** is installed, operated, and maintained in the following field installation configurations:

- on a fan of a Heating, Ventilating, Air Conditioning (HVAC) system behind an access panel or a cover;
- on a fan of an air purifier behind the cover; and
- on a ventilation fan behind a protective grill.

The product may also be installed by a manufacturer inside the HVAC system, inside the air purifier, or inside the fan.



Figure 1. Three-quarter view of greenfan® bipolar ionizer

The greenfan® bipolar ionizer shown in **Figure 1** is an Intertek® ETL-listed product and tested by Intertek® to conform to UL STD 867 and is certified to CSA C22.2 #187. Intertek® tests verified the 24-hour Time Weighted Average (TWA) ozone for this product is 0.0 parts per million by volume (ppmv) when tested in a 30 m³ chamber. The product is CARB-certified, meets the Intertek® Sustainability Verified Zero Ozone program, meets UL 2998, and does not emit more than 0.005 ppm as tested per UL 867.¹ The product is marked as 24 Volts Alternating Current (VAC) for installation in a Class 2 circuit.

The greenfan® bipolar ionizer unit is typically installed at the fan inlet to provide the highest concentration of positive and negative ions to neutralize odors and aerosol pathogens in the volumetric airflow passing through the fan.² Laboratory tests by

¹ <https://sustainabilitydirectory.intertek.com/images/certificates/524d5be7-1210-47b4-a0bc-c138d316eb3c/ZOZ-90160-2022a.pdf>

² The greenfan® bipolar ion concentration is approximately 200 million ions per cubic centimeter (ions/cc) at the carbon fiber electrodes and varies depending on installation and environment conditions and declines based on the volumetric airflow and distance from the carbon fiber electrodes.

greenfan® bipolar ionizer Model 1600-01

Innovative Bioanalysis demonstrate that the greenfan® bipolar ionizer reduces an initial SARS-CoV-2 Delta variant aerosol concentration by 97.6% in 60 minutes when installed on a blower fan circulating 160 cubic feet per minute (cfm) of air in a 1280 cubic foot (ft³) chamber.³ Compared to control tests, the SARS-CoV-2 Delta variant aerosol concentration reduction was 94.1% in 60 minutes. The SARS-CoV-2 Delta variant causes more severe COVID-19 disease than previous strains in unvaccinated persons.⁴ Actual results may vary depending on installation and environmental conditions.

The greenfan® bipolar ionizer shown in **Figures 3, 4, and 5** can be installed at the fan inlet or outlet and is electrically connected to a transformer and to control signals from a thermostat, air purifier, or ventilation fan, as described in these installation instructions.⁵



Figure 3. Front view of greenfan® bipolar ionizer



Figure 4. Side view greenfan® bipolar ionizer showing Caution label



Figure 4. Product meets Intertek® Sustainability Verified Zero Ozone

³ D. Lee. 2021. Efficacy of the GreenFan® Bipolar Ionizer Against Aerosolized SARS-CoV-2 DELTA VARIANT. Report 1112. Innovative Bioanalysis, 3188 Airway Ave., Suite D, Costa Mesa, CA 92626. <https://www.innovativebioanalysis.com/about-us/#accreditation>

⁴ Changes to the spike protein make the Delta variant (B.1.617.2 and AY lineages) up to 50% more transmissible than other COVID-19 variants. The Omicron (B.1.1.529) variant is like Delta Variant in terms of transmissivity and symptoms. <https://www.who.int/news/item/28-11-2021-update-on-omicron>.

⁵ For air purifiers and ventilation fans, the greenfan® bipolar ionizer may be installed on the fan outlet.

greenfan® bipolar ionizer Model 1600-01

NOTICE

The greenfan® bipolar ionizer should only be installed and used as directed in this installation manual or the 2-page tri-fold manual supplied with the product. Please read the entire installation manual, or the 2-page tri-fold manual, before installation or use. Do not use unless properly installed.

WARNING

No user serviceable parts inside. Do not modify the greenfan® bipolar ionizer without authorization. Unauthorized modifications may compromise electrical safety, electromagnetic compatibility (EMC), and regulatory compliance, and may result in hazardous operation.

ELECTROMAGNETIC INTERFERENCE

The greenfan® bipolar ionizer complies with FCC Part 15 electromagnetic interference (EMI) requirements. It causes no harmful interference and accepts any received interference without impacting its performance.

RECOMMENDATION

The American Society of Heating, Ventilating, and Air-conditioning Engineers (ASHRAE) recommends installing MERV 13 air filters or High Efficiency Particulate Air (HEPA) filters to remove airborne viral particles, dust, pollen, dust mites, pet dander, smoke, Volatile Organic Compounds (VOCs), and other airborne particles.⁶ Combining the bipolar ionizer with a MERV-8 or MERV-10 air filter may improve the effectiveness of PM1.0 particle removal. Control VOCs at the source and use adequate outdoor air ventilation to dilute VOCs. Do not install the greenfan® bipolar ionizer in buildings with high VOCs. The bipolar ionizer has not been evaluated by the FDA as a medical device, and is not intended to treat, cure, or prevent infections or diseases caused by certain viruses or bacteria. For technical product information, please contact:

support@greenfan.co.

2.0 TOOLS FOR INSTALLATION AND MAINTENANCE

- a) Wire nuts and self-tapping screws (1/4" drive or Phillips x 3/4" long) are supplied.
- b) Screw or nut drivers to remove or install screws.
- c) Wire cutter and wire stripper.
- d) Multimeter to measure current and or voltage.
- e) LED flashlight, vacuum cleaner or compressed air, small brush, or toothbrush.

⁶ ASHRAE currently recommends using MERV 13 filters which capture ≥0.30-1.0 µm (micron) particles at 50%, ≥1.0-3.0 µm at 85%, ≥3.0-10.0 µm at 90%. MERV 14 captures ≥1.0-3.0 µm at 90%. MERV 14 captures ≥0.30-1.0 µm at 75%, ≥1.0-3.0 µm at 90%, and ≥3.0-10.0 µm at 95%. MERV 8 captures ≥1.0-3.0 µm at 20%, ≥3.0-10.0 µm at 70%. MERV 10 captures ≥1.0-3.0 µm at 50%, ≥3.0-10.0 µm at 80%. HEPA filters capture ≥0.3 µm particles at 99.7% and airborne viral particles associated with SARS-CoV-2. [ashrae.org/technical-resources/filtration-and-disinfection-faq](https://www.ashrae.org/technical-resources/filtration-and-disinfection-faq)

greenfan® bipolar ionizer Model 1600-01

- f) For 120/208/240V installations order greenfan® accessory 120/208/240V to 24VAC Class 2 transformer Model 1601-01 (UL 5085-3 listed E65390). Class 2 transformers deliver 100W or less with maximum output voltage of 30VAC or less.
- g) For air purifier or ventilation fan installations order greenfan® accessory 120/24VAC class 2 transformer Model 1602-01 (UL-listed).

3.0 DISCONNECT POWER BEFORE INSTALLATION

CAUTION: Do not connect the unit to power until the mechanical and electrical installations are complete. For packaged units, disconnect power from the entire HVAC system. For split-systems disconnect power to the Forced Air Unit (FAU). For air purifiers or ventilation fans, disconnect power or unplug power cord before installation. All field wiring must comply with the National Electrical Code (NEC) or the National Fire Protection Association (NFPA) 70E-2021, and the Authorities Having Jurisdiction (AHJ).

4.0 HVAC FAN INSTALLATION

4.1 HVAC Fan Mechanical Installation

- a) **WARNING:** Do not connect the unit to power before the mechanical and electrical installation is complete.
- b) Mount greenfan® bipolar ionizer unit to allow access for general maintenance.
- c) Install unit with two self-tapping screws (1/4" drive x 3/4" long) attached through holes in flanges on either side of unit with at least one inch clearance between carbon fiber electrodes and metal surfaces or wires to ensure airflow over both electrodes. Secure wires with zip ties to maintain proper clearance.
- d) For the HVAC system, install the unit behind the panel on the fan inlet downstream of the air filter to reduce dust build-up on the carbon fiber electrode brushes, as shown in **Figure 6**.
- e) The greenfan® bipolar ionizer is installed on the fan inlet of a packaged or split system with airflow up to 2,400 cubic feet per minute (cfm) or 1132 liters per second (l/s). Install more than one unit when airflow exceeds 2,400 cfm (1,132 l/s).

greenfan® bipolar ionizer Model 1600-01

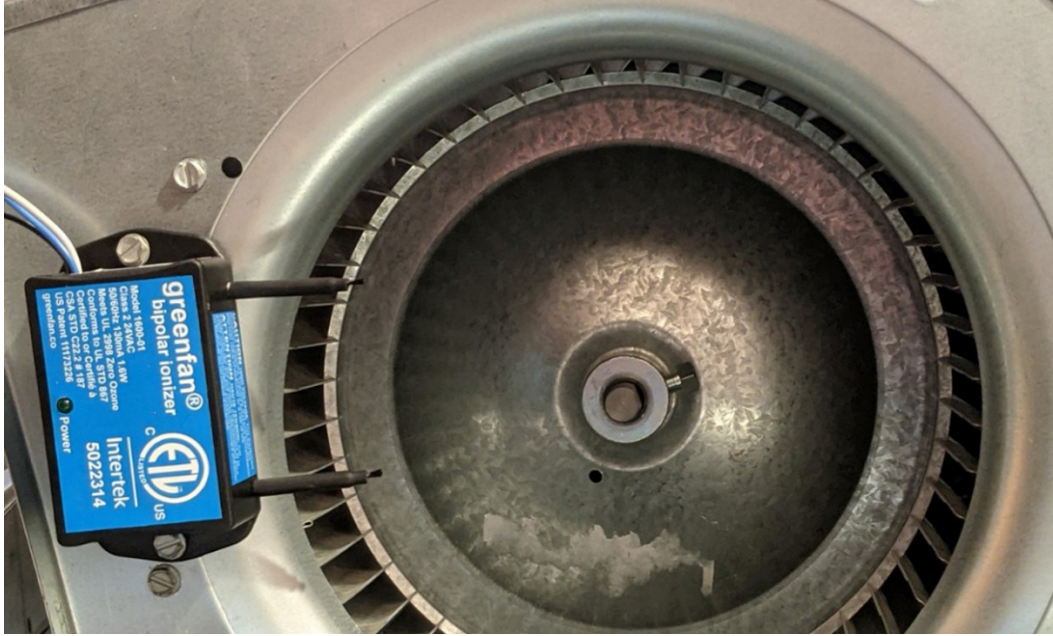

Figure 6. greenfan® bipolar ionizer installation at the fan inlet of an HVAC system

- f) Install a bipolar ionizer on a metal shroud with at least one inch clearance between electrodes and metal surfaces. Make sure the screws do not interfere with the fan blade movement. Manually rotate the fan blade after installation of the screws to verify that the screws do not interfere with fan rotation.
- g) Proceed to HVAC fan electrical installation.

4.2 HVAC Fan Electrical Installation with 24VAC Transformer

- a) Use multimeter to determine if 24VAC control signal wires are available. If yes go to step b. If no, go to step c.
- b) For 24VAC HVAC systems, refer to **Figure 7**. Loosen screws, insert wires (as shown), and tighten screws with all wires in place. Connect greenfan® bipolar ionizer blue wire to C terminal or to common wire of HVAC system. Connect black wire to fan G terminal or fan G wire of HVAC system. Connect white wire to heat W terminal or heat W wire of HVAC system. Skip to step d.
- c) For HVAC systems without accessible 24VAC control signal wires, install 120/208/240V to 24VAC Class 2 UL-listed transformer (Model 1601-01) shown in **Figure 8** and **Figure 9**. Connect 120/208/240V common wire of transformer to 120/208/240V common wire of HVAC system and connect greenfan® bipolar ionizer blue wire to one of 24VAC wires from transformer shown in **Figure 9**. Connect greenfan® bipolar ionizer black wire to other 24VAC wire from transformer and connect appropriate wire from 120/208/240V transformer to 120/208/240V hot wire of fan. Transformer wire color may vary. Install wire nut to insulate white wire of greenfan® bipolar ionizer shown in **Figure 9**.
- d) After completing all steps of mechanical and electrical installation for HVAC system proceed to HVAC fan verification of proper operation.

greenfan® bipolar ionizer Model 1600-01

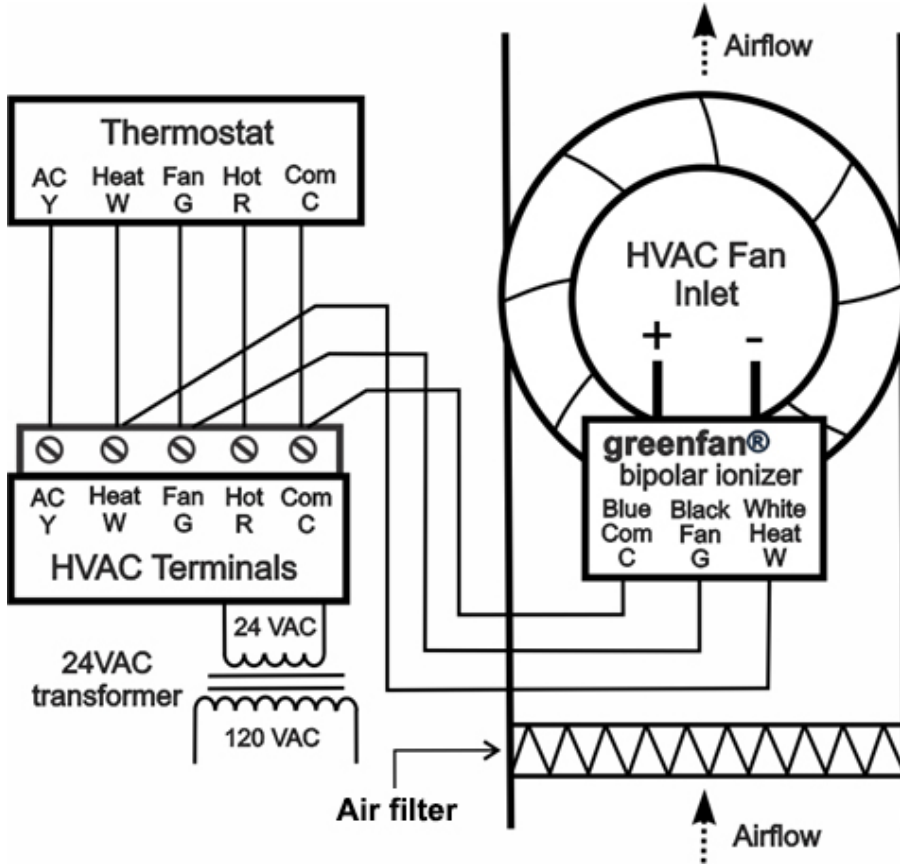

Figure 7. Schematic of HVAC Fan Electrical Installation with 24VAC Transformer

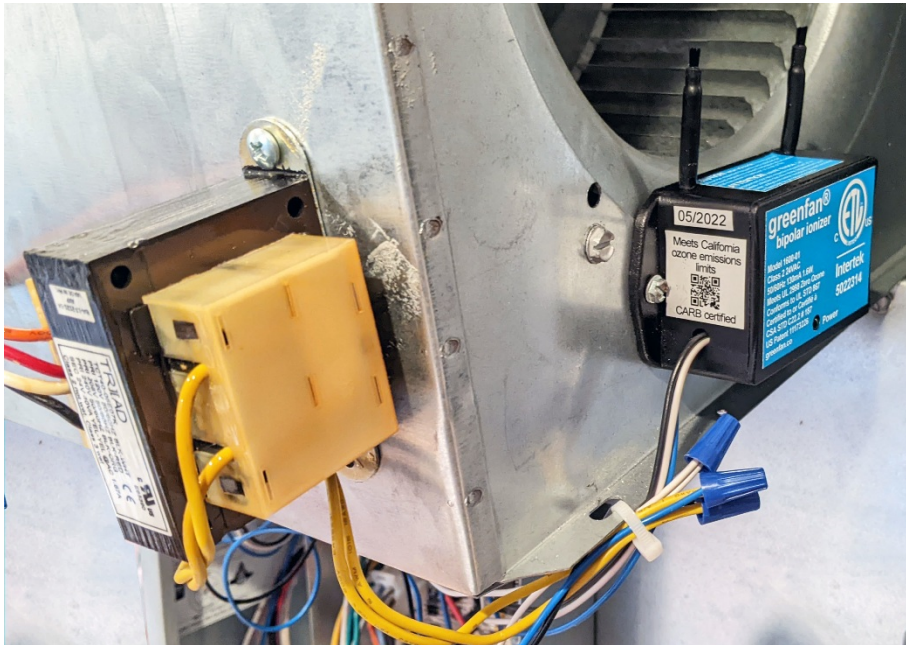

Figure 8. Bipolar ionizer installed with 120/208/240V to 24VAC transformer

greenfan® bipolar ionizer Model 1600-01

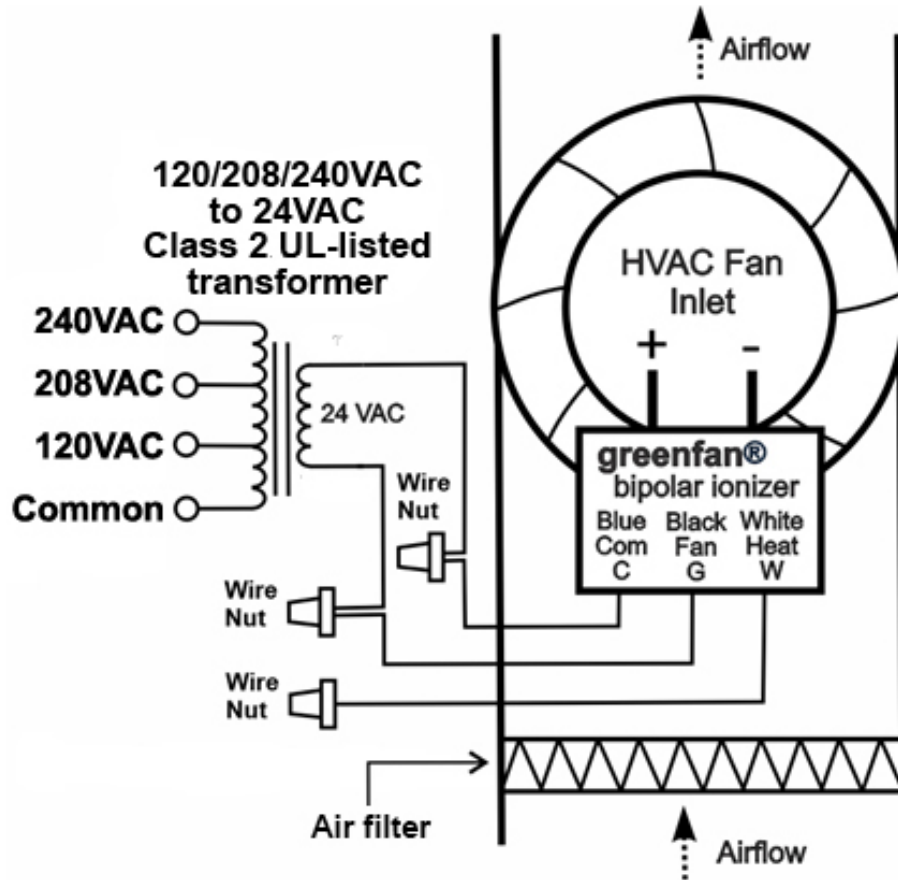

Figure 9. Installation schematic with 120/208/240V to 24VAC transformer

4.3 HVAC Fan Verification of Proper Operation

- Verify all wires are correctly connected and wire nuts are tight and secure.
- Temporarily close safety switch on access panel door and jumper fan to turn on fan and greenfan® bipolar ionizer and verify LED lamp is illuminated on front of unit indicating ions are being generated with airflow.
- Turn off power and verify LED lamp is not illuminated.
- Close access panel of HVAC system or FAU after verifying operation.**

5.0 AIR PURIFIER INSTALLATION

5.1 Air Purifier Mechanical Installation

- WARNING:** Disconnect electrical power from the air purifier before and during installation. Do not connect electrical power until installation is completed.
- For air purifier, install unit with two self-tapping screws (1/4" drive x 3/4" long) attached through holes in flanges on either side of unit with at least one inch clearance between carbon fiber electrodes and metal surfaces to ensure airflow over both electrodes. Install greenfan® bipolar ionizer unit behind cover and downstream of air filter to reduce dust build-up and allow airflow to pass over carbon fiber electrode brushes as shown in **Figure 10**. Make sure screws do not interfere with the fan blade movement. Manually rotate fan blade after installation of screws to verify screws do not interfere with fan rotation. Make sure wires are secured with zip

greenfan® bipolar ionizer Model 1600-01

ties and more than one inch away from greenfan® bipolar ionizer carbon fiber electrode brushes.

- c) After completing all steps of mechanical installation proceed to electrical installation.



Figure 10. greenfan® bipolar ionizer installation at fan inlet of an air purifier

5.2 Air Purifier Electrical Installation

- Air purifier electrical installation requires UL-listed 120/24VAC transformer (Model 1602-01). Use multimeter to locate 120VAC wire to fan motor and use in-line splices to connect 120/24VAC transformer wire to 120VAC fan motor wire and 120/24VAC transformer common wire to 120VAC neutral wire shown in **Figure 11**.
- Connect greenfan® bipolar ionizer blue wire to one wire of 24VAC transformer and connect greenfan® bipolar ionizer black wire to other wire of 24VAC transformer.
- Install wire nut to insulate unused white wire of greenfan® bipolar ionizer.
- The greenfan® bipolar ionizer will draw less than 130mA and 1.6W or greater at 24VAC and 50/60 Hz when air purifier or fan is energized or turned on.
- After completing all steps of the air purifier mechanical and electrical installation proceed to air purifier verification of proper operation.

5.3 Air Purifier Verification of Proper Operation

- Verify all wires are correctly connected and wire nuts are tight and secure.
- Plug in air purifier, turn on power, turn on fan, and verify green LED lamp is illuminated on greenfan® bipolar ionizer indicating ions are being generated.
- Turn off the power and verify LED lamp is not illuminated.
- Install cover panel of the air purifier.

greenfan® bipolar ionizer Model 1600-01

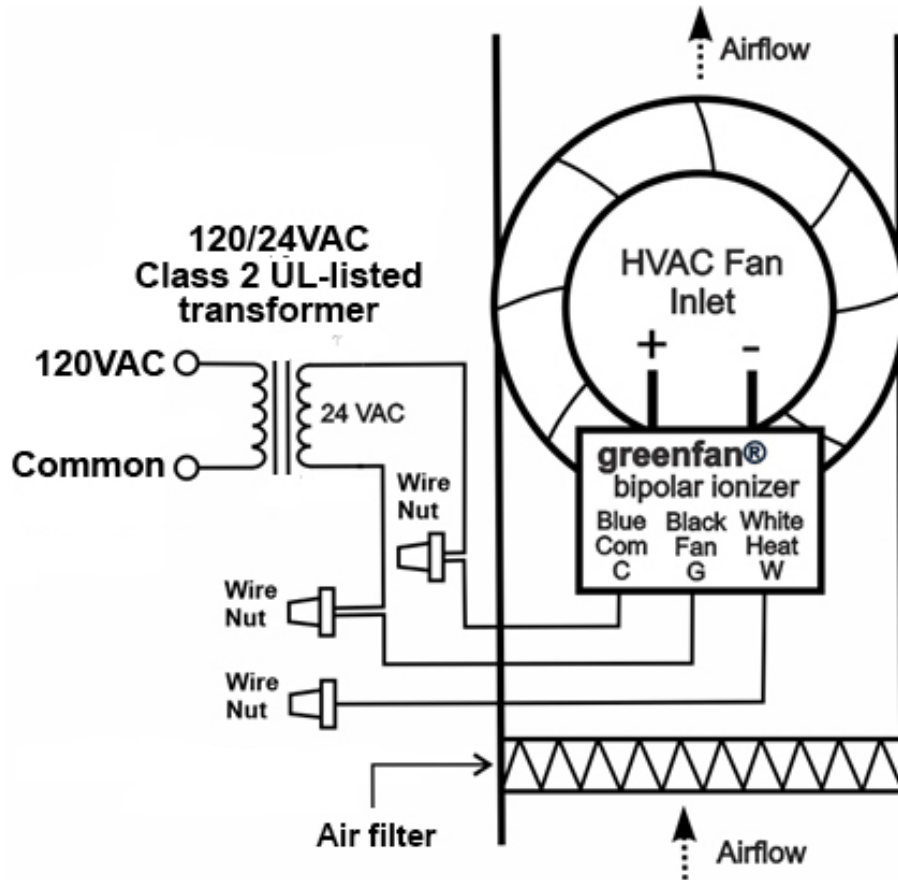

Figure 11. Installation schematic with 120/24VAC transformer

6.0 VENTILATION FAN INSTALLATION

6.1 Ventilation Fan Mechanical Installation

- WARNING:** Disconnect electrical power from the ventilation fan before and during installation. Do not connect electrical power until installation is completed.
- For ventilation fan, install greenfan® bipolar ionizer behind protective grill of fan on a 22-gauge sheet metal support (supplied by installer) attached to a vertical bracket holding fan motor with two self-tapping screws (1/4" drive x 3/4" long) attached through holes in flanges on either side of unit with at least one inch clearance between carbon fiber electrodes and metal surfaces to ensure airflow over both electrodes as shown in **Figure 12**. Make sure any wires secured with zip ties and located more than one inch away from greenfan® bipolar ionizer carbon fiber electrode brushes. Make sure screws do not interfere with wires or fan blade movement. Manually rotate fan blade after installation to verify screws do not interfere with fan rotation.
- After completing all steps of mechanical installation proceed to electrical installation.

greenfan® bipolar ionizer Model 1600-01



Figure 12. Bipolar ionizer installed at inlet of ventilation fan behind protective grill

6.2 Ventilation Fan Electrical Operation

- Ventilation fan electrical installation requires UL-listed 120/24VAC transformer (Model 1602-01). Use multimeter to locate 120VAC wire to fan motor and use in-line splices to connect 120/24VAC transformer wire to 120VAC fan motor wire and 120/24VAC transformer common to 120VAC neutral wire shown in **Figure 11**.
- Connect greenfan® bipolar ionizer blue wire to one wire of 24VAC transformer and connect greenfan® bipolar ionizer black wire to other wire of 24VAC transformer.
- Install wire nut to insulate unused white wire of greenfan® bipolar ionizer.
- The greenfan® bipolar ionizer will draw less than 130mA and 1.6W or greater at 24VAC and 50/60 Hz when energized when ventilation fan is turned on.
- After completing all steps of mechanical and electrical installation proceed to ventilation fan verification of proper operation.

6.3 Ventilation Fan Verification of Proper Operation

- Verify all wires are correctly connected and wire nuts are tight and secure.
- Install protective grill before turning on power to the ventilation fan.**
- Plug in ventilation fan, turn on fan, and verify green LED lamp is illuminated on greenfan® bipolar ionizer indicating ions are being generated.
- Turn off power and verify LED lamp is not illuminated.

7.0 OPERATING NOTES

Follow all local, state, and national electrical and building codes.

- The greenfan® bipolar ionizer is designed to operate at temperatures at or below 140F or 60C.
- The greenfan® bipolar ionizer is designed for 24VAC operation only.

greenfan® bipolar ionizer Model 1600-01

- c) When power is supplied, the greenfan® bipolar ionizer will be energized and the LED will be illuminated.
- d) The greenfan® bipolar ionizer is self-balancing and does not require any adjustment.
- e) The greenfan® bipolar ionizer must be installed inside the HVAC equipment, air purifier, or fan. L'ioniseur bipolaire greenfan® doit être installé à l'intérieur de l'équipement CVC, du purificateur d'air ou du ventilateur.
- f) This air cleaner shall not be installed on the hot-air side of duct-type systems. Ce filtre à air ne doit pas être installé du côté air chaud des systèmes de type conduit.

8.0 TROUBLESHOOTING

- a) If LED lamp is continuously illuminated when thermostat fan switch, air purifier, or fan is turned to the ON position, then bipolar ionizer is operating properly. The greenfan® bipolar ionizer continuously monitors high-voltage signals on the positive-ion electrode and the negative-ion electrode to maintain consistent high-voltage and balanced bipolar ion concentrations over a range of voltage inputs from 20 to 30VAC. For HVAC systems without easily accessible 24VAC wires nearby install a 120/208/240V to 24VAC UL-listed transformer shown in **Figure 8** and **Figure 9**.
- b) If LED lamp does not illuminate when thermostat fan switch, air purifier, or fan is turned to the ON position, then check: 1) power supply or transformer is plugged in and operating properly; 2) bipolar ionizer is properly connected to power supply or transformer (check all wire nut connections); 3) verify all wire and wire nut connections are correct and tight; and 4) reconnect any loose wires as necessary and verify operation as described above.
- c) If LED lamp is flashing when thermostat fan switch, air purifier, or fan is turned to the ON position, then check: 1) power supply voltage input is within 20 to 30VAC; and 2) electrical shorts on the positive-ion electrode or the negative-ion electrode.
- d) If above steps do not correct flashing or non-illuminated LED lamps, then please contact technical support.
- e) Technical support: support@greenfan.co, 877-777-6756, www.greenfan.co/contact. GreenFan® Inc., 357 W. Grove Ave., Orange, CA 92865.

9.0 MAINTENANCE

The following maintenance procedure is recommended.

- a) Turn power off to FAU or packaged HVAC system or air purifier or ventilation fan.
- b) Open access panel on FAU or packaged HVAC system or cover of air purifier or fan.
- c) With access panel or cover open, use LED lamp to locate greenfan® bipolar ionizer on fan inlet and carefully clean carbon fiber electrode brushes with soft non-abrasive cloth, small brush, or toothbrush. **CAUTION: Carefully clean carbon fiber electrode brushes to avoid damaging brushes.** Inspect equipment frequently and remove collected dirt regularly to prevent excessive accumulation that may result in flashover or a risk of fire.
- d) Install MERV 8 (or better) electrostatically charged pleated air filters with activated carbon to remove dust, pollen, dust mites, pet dander, smoke, Volatile Organic Compounds (VOCs), and other airborne particles.
- e) Remove tools and close access panel on FAU or packaged HVAC system or cover of air purifier or ventilation fan.

greenfan® bipolar ionizer Model 1600-01

- f) Turn on power to the FAU or packaged HVAC system or air purifier or fan.

10.0 SAFETY INSTRUCTIONS

- a) This product complies with the maximum allowable concentration of ozone of 0.050 parts per million by volume (ppmv) in a 24-h period.
- b) The 8-hr TWA ozone for this product is 0.0 ppmv when tested in a 30 m³ chamber.
- c) Intertek® Sustainability Verified Zero Ozone: This product meets UL 2998 and does not emit more than 0.005 ppm as tested per UL 867.
- d) CAUTION HIGH VOLTAGE: This equipment should be inspected frequently and collected dirt removed from it regularly to prevent excessive accumulation that may result in flashover or a risk of fire.

CONSIGNES DE SÉCURITÉ

- a) Ce produit est conforme à la concentration maximale admissible d'ozone de 0,050 partie par million en volume (ppmv) sur une période de 24 heures.
- b) L'ozone TWA sur 8 heures pour ce produit est de 0,0 ppmv lorsqu'il est testé dans une chambre de 30 m³.
- c) Intertek® Sustainability Verified Zero Ozone: Ce produit est conforme à la norme UL 2998 et n'émet pas plus de 0,005 ppm selon les tests de la norme UL 867.
- d) ATTENTION HAUTE TENSION: Cet équipement doit être inspecté fréquemment et la saleté collectée doit en être retirée régulièrement pour éviter une accumulation excessive pouvant entraîner un embrasement ou un risque d'incendie.

11.0 WARRANTY

GREENFAN® hereby warrants to the consumer that the product purchased under this warranty be free from defects in material and workmanship under normal use when installed, operated, and maintained in accordance with manufacturer's instructions. In the event of a product defect, failure, or malfunction, GREENFAN® will, for a period of five (5) years from the date of purchase, repair or replace at its discretion the defective, failed, or malfunctioning product purchased under this Warranty. Installation and/or removal labor is not covered under this Warranty.

Warranty, return, or repair requests must be processed at www.greenfan.co/contact.

The following information is required for processing a warranty, return, or repair request:

- 1) purchases made and received within the USA; 2) product registration or proof of purchase may be required; 3) excludes filters and parts intended for regular replacement; 4) normal recommended use at the recommended input voltages on the product label or installation manual. Warranty, return, or repair requests are not provided for products that are damaged due to incorrect installation, physical abuse, chemical exposure, water damage, fire damage, or input voltage outside the recommended input voltage on the product label or instruction manual, or service of product by anyone other than GREENFAN® technicians or authorized dealers. Products covered by the warranty, return or repair may be replaced with new or refurbished units of the same or similar model. Liability for damages to you for any costs whatsoever arising out of this statement of warranty shall be limited to the amount paid for this product at the time of original purchase, and GREENFAN® shall not be liable for

greenfan® bipolar ionizer Model 1600-01

any direct, indirect, consequential, or incidental damages arising out of the use or inability to use the product. An RMA# is required for warranty, return, or repair requests. Returned packages without an RMA# will be refused. For warranty information, please contact: support@greenfan.co or call 1-877-777-6756.

Other than as herein expressly set forth, there are no warranties, expressed or implied, including, without limitation, the warranties of merchantability and fitness for a particular purpose, any such warranties otherwise imposed by the law being hereby expressly disclaimed.

Some states do not allow limitations on the duration of an implied warranty, so the above limitation may not apply.

GREENFAN® is not and shall under no circumstances be liable or responsible for any special, incidental, or consequential damages, losses, or expenses arising from a claimed or actual defect in any of the products purchased under this warranty or the installation or use thereof or from any other cause whatsoever, including, but not limited to, loss of profits, loss of business, loss of revenues, and other economic loss.

Some states do not allow the exclusion or limitation of incidental or consequential damages, so the above limitation or exclusion may not apply.

greenfan® bipolar ionizer Model 1600-01

12.0 SPECIFICATIONS

Operational	Model 1600-01 airflow Bipolar ion concentration	Up to 2400 cfm or 1133 l/s Approximately 200 million ions per cubic centimeter (ions/cc) at the carbon fiber electrodes, and varies depending on installation and environmental conditions, and declines based on the volumetric airflow and distance from the carbon fiber electrodes
	Ozone	24-hr TWA ozone is 0.0 ppmv when tested in a 30 m3 chamber by Intertek®
	Warranty	5-years limited warranty
	Standards	Intertek Sustainability Verified Zero Ozone meets UL 2998, conforms to UL 867, and is certified to CSA 22.2 #184
	US Patents	11173226 B1, 11563310 B2, 12038204 B2
	SARS-CoV-2 delta variant virus which causes more severe COVID-19 disease than previous strains in unvaccinated persons	Bio-Safety Level-3 (BSL-3) laboratory tests by Innovative Bioanalysis demonstrate that the greenfan® bipolar ionizer reduced an initial SARS-CoV-2 Delta Variant aerosol concentration of 4.03×10^6 Median Tissue Culture Infectious Dose per milliliter of sample (TCID50/ml) to 9.85×10^4 TCID50/ml, achieving a 97.6% reduction within 60 minutes, 74.5% reduction within 30 minutes, and 45% reduction within 15 minutes when installed on the inlet of a blower fan circulating air in a 20' x 8' x 8' chamber.
Electrical	Model 1600-01	24VAC 1.6Watts, 130mAmps, 50/60Hz, resettable fuse Provides consistent high-voltage output at carbon fiber electrodes over a range of input voltages from 20 to 30 VAC
	Accessory Model 1601-01	For 120/208/240V installations, order greenfan® model 1601-01: 120/208/240V to 24VAC Class 2 transformer (UL 5085-3 listed E65390). Class 2 refers to a transformer that delivers 100W or less with a maximum output voltage of
	Accessory Model 1602-01	For 120/24VAC air purifier and ventilation fan installations, order greenfan® model 1602-01: 120/24VAC Class 2 transformer (UL-listed)
	Input voltage	30VAC or less
Mechanical	1600-01 dimensions	3.054" W x 2.129" H x 1.25" D without flange UL 94V-0 4.053" W x 2.129" H x 1.25" D with flanges UL 94V-0 4.053" W x 3.754" H x 1.25" D with electrodes (0.28 mil 6K carbon fiber TOW) Plastic case tolerances: +/-0.015 Carbon fiber electrode height tolerance: +/- 0.030
	Unit Weight	7.1 ounces
Environmental Conditions	1600-01 environmental conditions	Operating/Storage/Transport Temperature: -40 to 71° C (-40 to 160°F) Relative Humidity (RH): 0 to 100%, including condensing environments, without causing deterioration.
Manufacturing Contact	1600-01 contacts	Manufacturer: Greenfan® Inc. 353 W Grove Ave. Orange CA 92865 Contact: support@greenfan.co , 844-804-7336